



A Short Tutorial on Domain Generalization

[Christos Diou](#) & [Aristotelis Ballas](#)

Department of Informatics and Telematics
Harokopio University of Athens, Greece

Outline

Part 1: Introduction to DG

Part 2: Overview of representative DG methods

Part 3: DG datasets and benchmarks

Part 4: DG for biomedical signals: The BioDG benchmark

Part 5: Conclusions

Part 1: Introduction to the Domain

Generalization problem



(A) **Cow: 0.99**, Pasture:
0.99, Grass: 0.99, No Person:
0.98, Mammal: 0.98

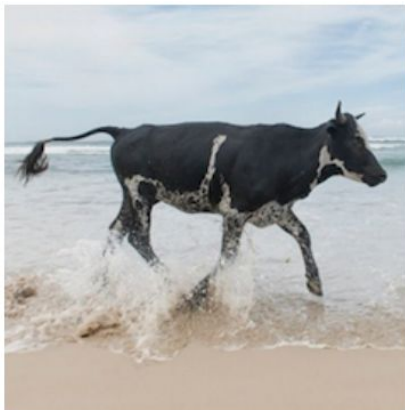

(B) No Person: 0.99, Water:
0.98, Beach: 0.97, Outdoors:
0.97, Seashore: 0.97



(C) No Person: 0.97,
Mammal: 0.96, Water: 0.94,
Beach: 0.94, Two: 0.94

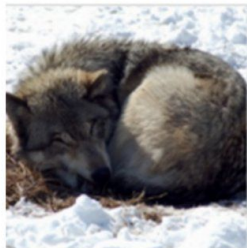

Predicted: **wolf**
True: **wolf**



Predicted: **husky**
True: **husky**



Predicted: **wolf**
True: **wolf**

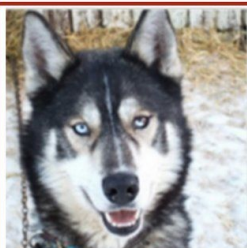

Predicted: **wolf**
True: **husky**

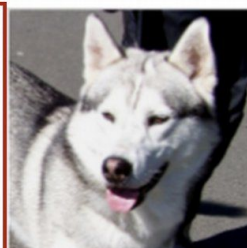

Predicted: **husky**
True: **husky**



Predicted: **wolf**
True: **wolf**

Background (1)

Supervised statistical machine learning methods aim at learning a function

$$\hat{y} = f(x; \theta)$$

which provides an estimate/probabilities \hat{y} of the true value of the label(s)/target(s) y , given a previously unseen data sample x

In our previous example, $x =$



$\hat{y} =$ (A) **Cow: 0.99**, Pasture:
0.99, Grass: 0.99, No Person:
0.98, Mammal: 0.98

Background (2)

Let P_{XY} on $\mathcal{X} \times \mathcal{Y}$ be the distribution of the training data. A fundamental assumption of most ML methods is that the unseen (test) data follow the same distribution as the training data (i.i.d. assumption).

However, in our example:



(1): Cows + grass

$$P_{XY}^{(1)} \neq P_{XY}^{(2)}$$

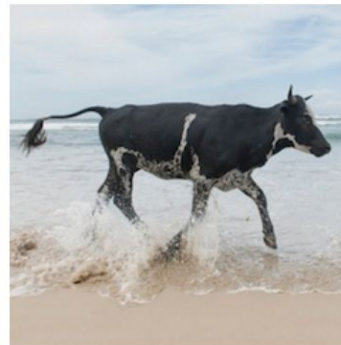

(2): Cows + beach

Domains

Let's call each $P_{XY}^{(i)}$, $i = 1, \dots, K$ a **domain**

Example domains:

- Cows with grass
- Cows with beach
- Wolves with snow
- Wolves with gravel

Domains

Let's call each $P_{XY}^{(i)}$, $i = 1, \dots, K$ a **domain**

Example domains:

- Cows with grass
- Cows with beach
- Wolves with snow
- Wolves with gravel

Problem 1: How can we train a model to correctly classify samples from different domains?

Solution 1: Just train a model with pictures from both domains

Domains

Let's call each $P_{XY}^{(i)}$, $i = 1, \dots, K$ a **domain**

Example domains:

- Cows with grass
 - Cows with beach
 - Wolves with snow
 - Wolves with gravel
- Dataset distribution can be device-specific
 - X-rays of device A
 - X-rays of device B
 - Dataset distribution may vary across individuals
 - Blood sample from person 1
 - Blood sample from person 2
 - Privacy / legal / technical restrictions

Problem 2: In many real-world scenarios it is difficult to have access to large volumes of data from all domains during training

Transfer learning (for the same labels)

Given a model trained on a **source domain**: $P_{XY}^{(S)}$

Train a model on the **target domain**: $P_{XY}^{(T)}$ by performing a (hopefully small) number of training iterations

Requirements:

- Large numbers of labeled data on source domain
- Availability of labeled data on target domain



Domain adaptation

Train a model on the **source domain(s)**: $P_{XY}^{(S)}$

Use unlabeled data (or very small number of labeled data) to adapt the model to the **target domain**, $P_{XY}^{(T)}$

Requirements:

- Unlabelled data (or small number of labeled data) from the target domain

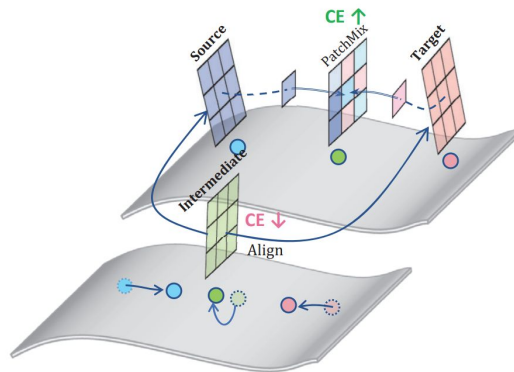
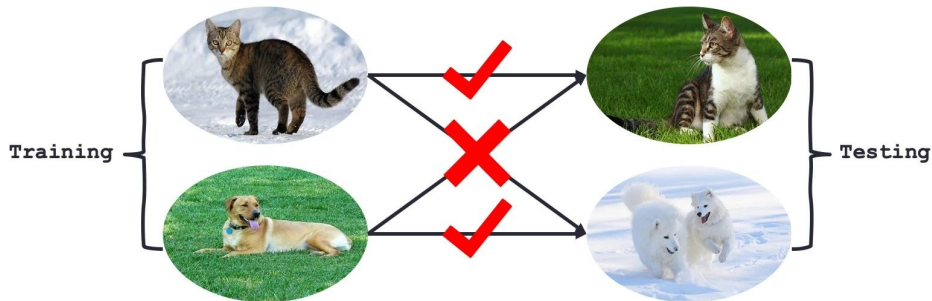

Image from: Zhu, J. et al. "Patch-Mix Transformer for Unsupervised Domain Adaptation: A Game Perspective.", CVPR 2023

Domain Generalization (1)

In this scenario we don't have access to **any** data from the target domain during training.

Our goal is to train a model using data from the source domain(s) that are effective in the unseen target domain(s)



Domain Generalization (2)

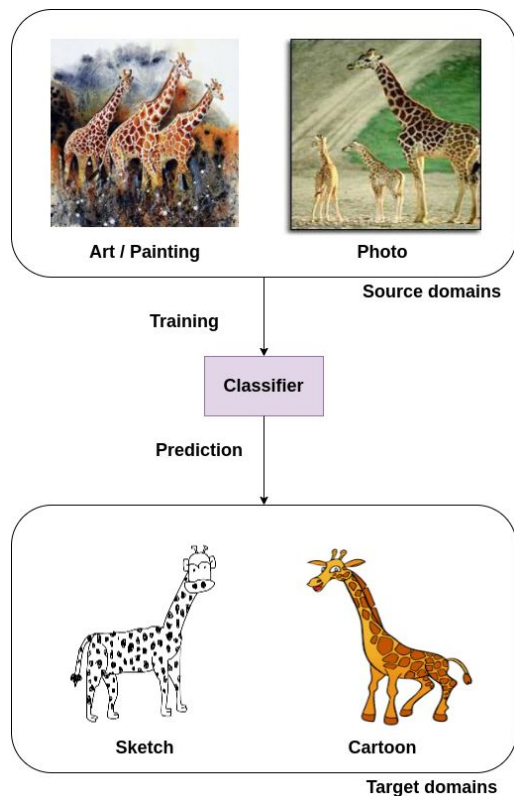

Sample images from the PACS dataset

Observation:

- Some features are common (invariant) across domains

Goal: Learn the invariant features, not spurious domain features

- **Multi-source DG:** Multiple training domains, access to domain labels (we know the domain of each training sample)
- **Single-source DG:** Single training domain and/or no-access to domain labels

Overview

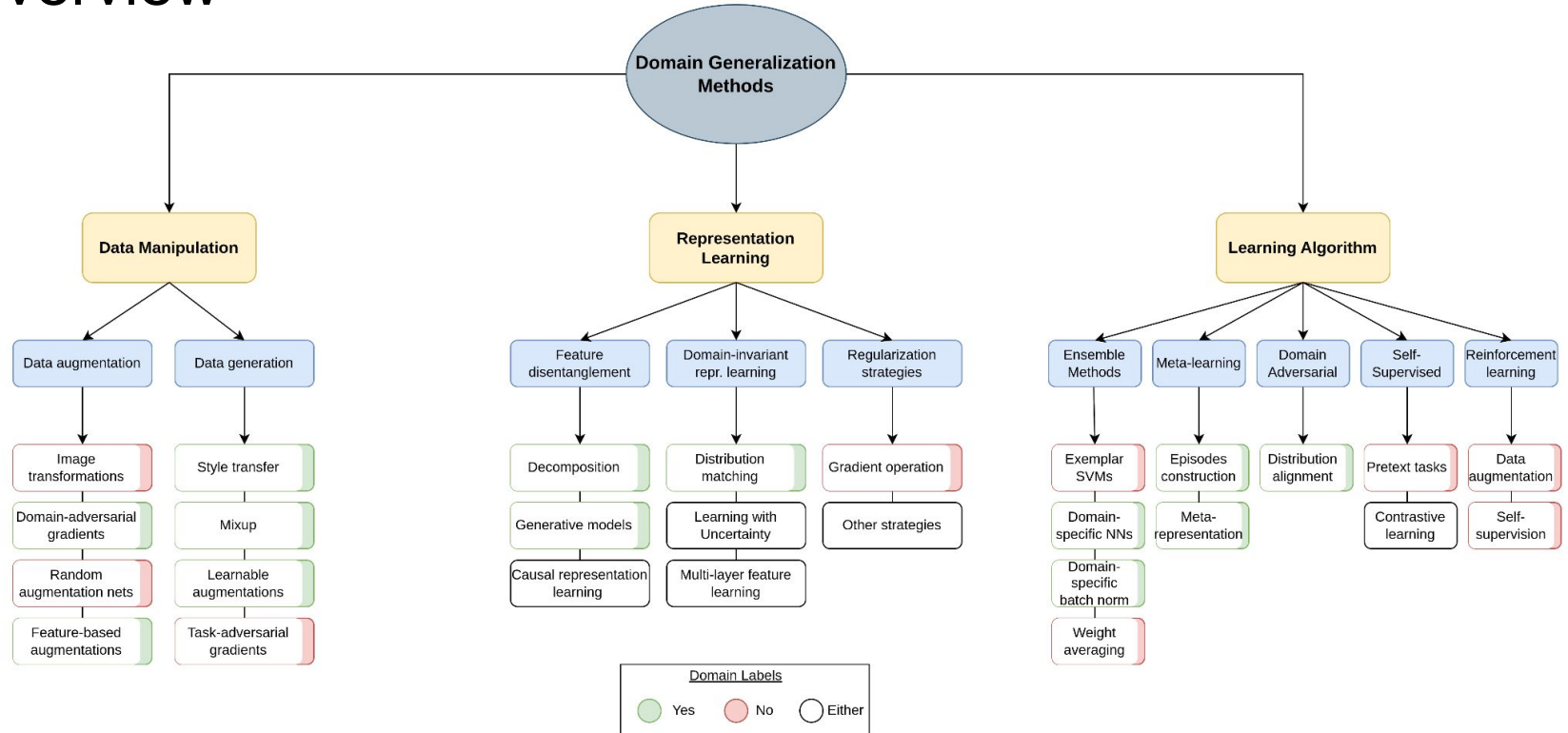

This taxonomy is a variation / extension of the ones on Wang, J. et al. "Generalizing to unseen domains: A survey on domain generalization." IEEE Transactions on Knowledge and Data Engineering (2022), and Zhou, Kaiyang, et al. "Domain generalization: A survey." IEEE Transactions on Pattern Analysis and Machine Intelligence (2022).

Part 2: Overview of representative DG methods

Data manipulation

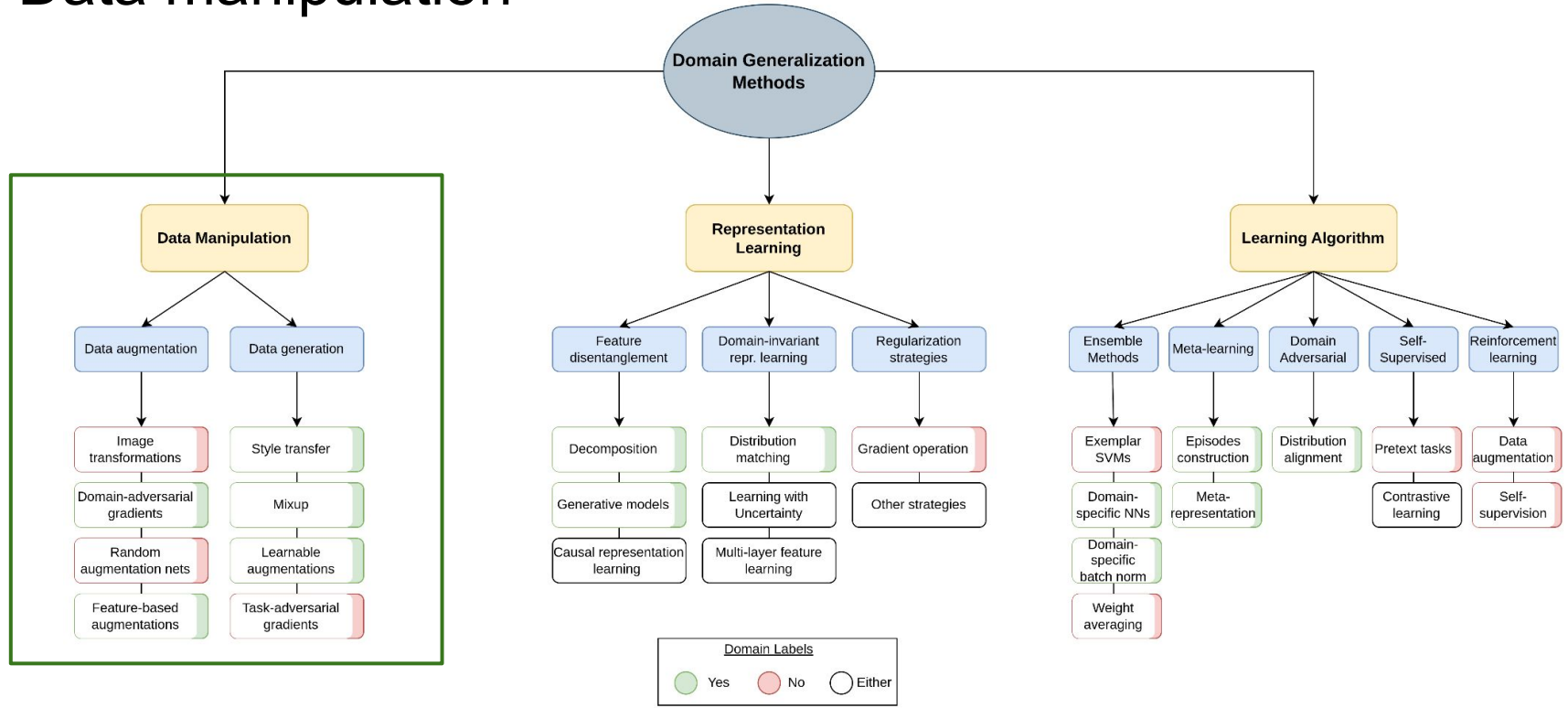

This taxonomy is a variation / extension of the ones on Wang, J. et al. "Generalizing to unseen domains: A survey on domain generalization." IEEE Transactions on Knowledge and Data Engineering (2022), and Zhou, Kaiyang, et al. "Domain generalization: A survey." IEEE Transactions on Pattern Analysis and Machine Intelligence (2022).

Data Augmentation

RandConv: Random Convolutions

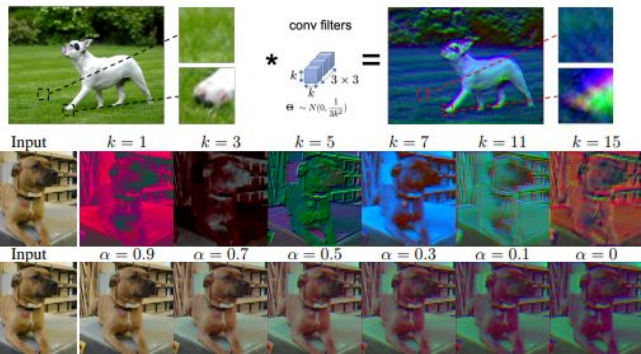

RandConv uses multi-scale random-convolutions to generate images with random texture while maintaining global shapes

Xu et al. Robust and Generalizable Visual Representation Learning via Random Convolutions. ICLR 2021.

CrossGrad: Cross-Gradient

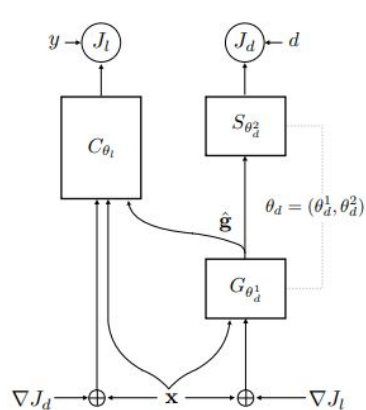

Adversarially augment data via gradient training to generate data that share the same label y but different domain label d .

Algorithm 1 CROSSGRAD training pseudocode.

- 1: **Input:** Labeled data $\{(x_i, y_i, d_i)\}_{i=1}^M$, step sizes ϵ_l, ϵ_d , learning rate η , data augmentation weights α_l, α_d , number of training steps n .
- 2: **Output:** Label and domain classifier parameters θ_l, θ_d
- 3: Initialize θ_l, θ_d $\{J_l, J_d$ are loss functions for the label and domain classifiers, respectively}
- 4: **for** n training steps **do**
- 5: Sample a labeled batch (X, Y, D)
- 6: $X_d := X + \epsilon_l \cdot \nabla_X J_d(X, D; \theta_d)$
- 7: $X_l := X + \epsilon_d \cdot \nabla_X J_l(X, Y; \theta_l)$
- 8: $\theta_l \leftarrow \theta_l - \eta \nabla_{\theta_l} ((1 - \alpha_l) J_l(X, Y; \theta_l) + \alpha_l J_l(X_d, Y; \theta_l))$
- 9: $\theta_d \leftarrow \theta_d - \eta \nabla_{\theta_d} ((1 - \alpha_d) J_d(X, D; \theta_d) + \alpha_d J_d(X_l, D; \theta_d))$
- 10: **end for**

Shankar et al. Generalizing across Domains via Cross-Gradient Training. ICLR 2018.

Data Generation

Mixup: Improve model robustness by training the network on convex combinations of pairs of examples and their labels.

Style transfer: Applying the AdaIN transformation to features can lead decoders to change the style of the input

MixStyle: Mix the styles of training instances in each mini-batch to increase the domain diversity of the source domains

$$\begin{aligned}\tilde{x} &= \lambda x_i + (1 - \lambda)x_j, \\ \tilde{y} &= \lambda y_i + (1 - \lambda)y_j, \\ \text{where } \lambda &\in [0, 1]\end{aligned}$$

$$AdaIN(x) = \sigma(y) \frac{x - \mu(x)}{\sigma(x)} + \mu(y)$$

$$MixStyle(x) = \gamma_{mix} \frac{x - \mu(x)}{\sigma(x)} + \beta_{mix}$$

$$\begin{aligned}\gamma_{mix} &= \lambda\sigma(x) + (1 - \lambda)\sigma(\tilde{x}), \\ \beta_{mix} &= \lambda\mu(x) + (1 - \lambda)\mu(\tilde{x}), \\ \text{where } \lambda &\sim Beta(a, a)\end{aligned}$$

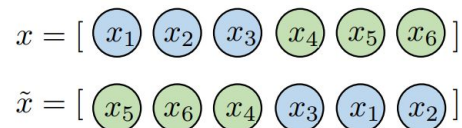
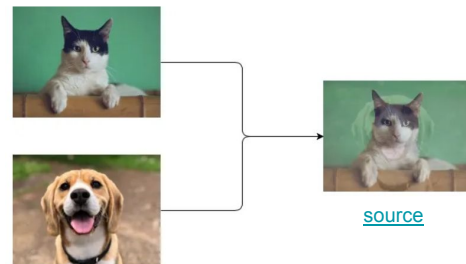

(a) Shuffling batch w/ domain label

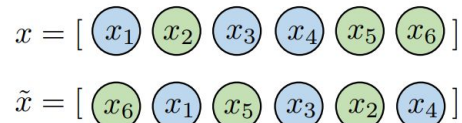

Representation learning

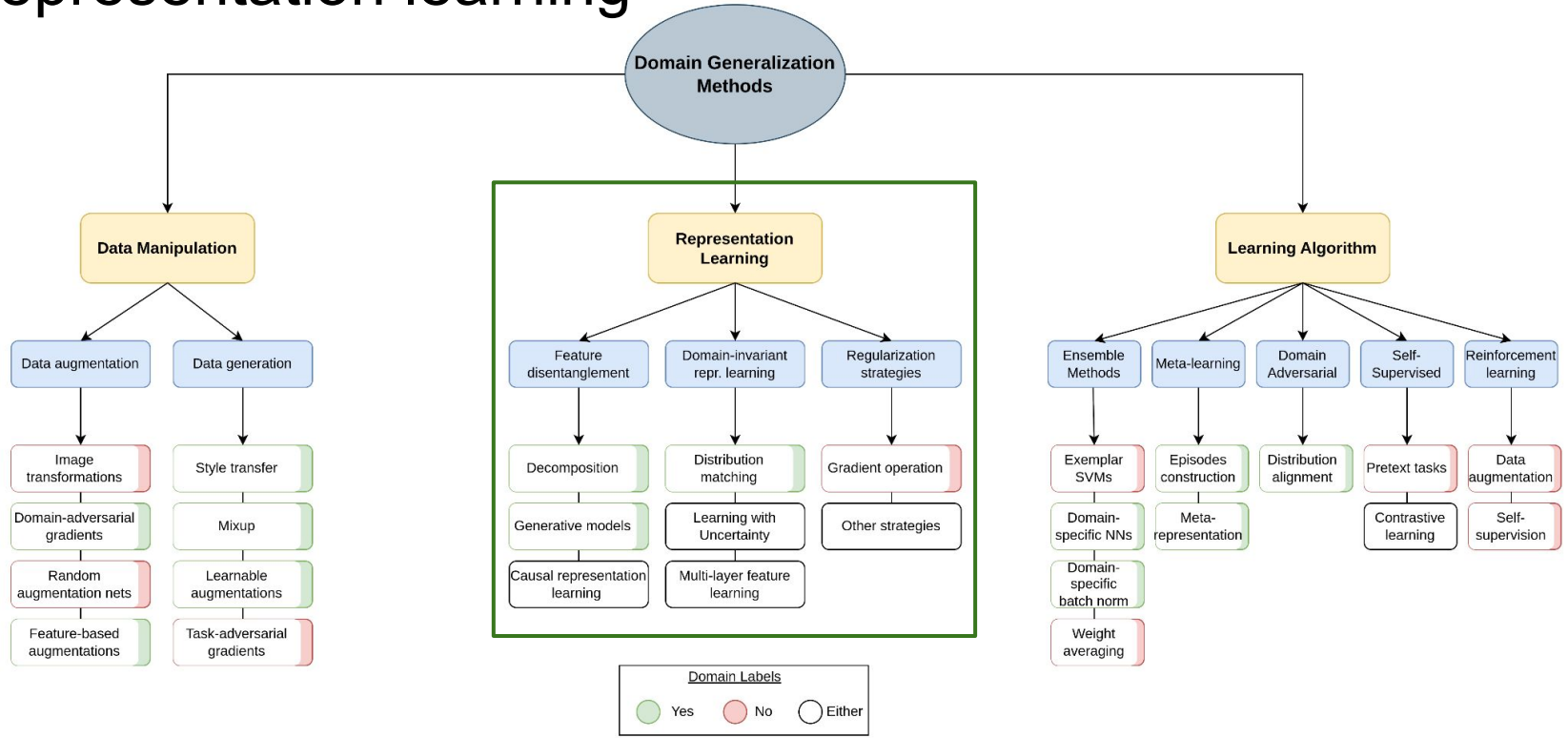

This taxonomy is a variation / extension of the ones on Wang, J. et al. "Generalizing to unseen domains: A survey on domain generalization." IEEE Transactions on Knowledge and Data Engineering (2022), and Zhou, Kaiyang, et al. "Domain generalization: A survey." IEEE Transactions on Pattern Analysis and Machine Intelligence (2022).

Feature Disentanglement

SagNet: Style Agnostic Networks

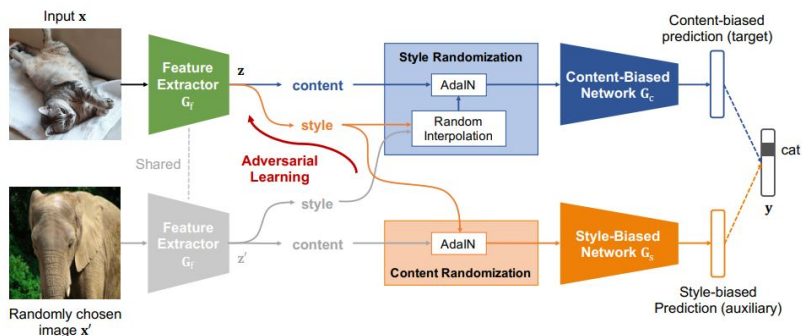

SagNets disentangle style encodings from class categories to prevent style biased predictions and focus more on the contents.

Nam et al. "Reducing domain gap by reducing style bias". CVPR 2021.

DDG: Disentanglement-constrained DG

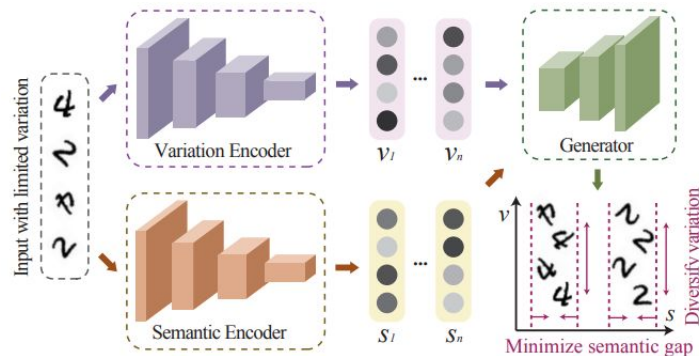

Zhang et al. "Towards Principled Disentanglement for Domain Generalization". CVPR 2022

Definition 3 (Constrained domain generalization problem) Given a fixed margin $\gamma > 0$, with Assumption 3 and enforcing the invariance on the semantic featurizer f_s , we transform the vanilla formulation Eq. (2) to the following inequality-constrained optimization

$$\begin{aligned} \mathcal{P}^* &\triangleq \min_{f_s \in \mathcal{F}} \mathcal{L}(f_s) \triangleq \mathbb{E}_{\mathbb{P}(X, Y)} \ell(f_s(X), Y), \\ \text{s.t. } &d(\mathbf{x}, D(f_s(\mathbf{x}; \theta), f_v(\tilde{\mathbf{x}}; \phi))) \leq \gamma, \text{ a.e. } \mathbf{x}, \tilde{\mathbf{x}} \sim \mathbb{P}(X). \end{aligned} \quad (3)$$

DDG seeks to minimize the semantic difference of the generated samples from the same class while diversifying the variation across source domains.

Domain Invariant Representation Learning

DSU: Domain Shifts with Uncertainty

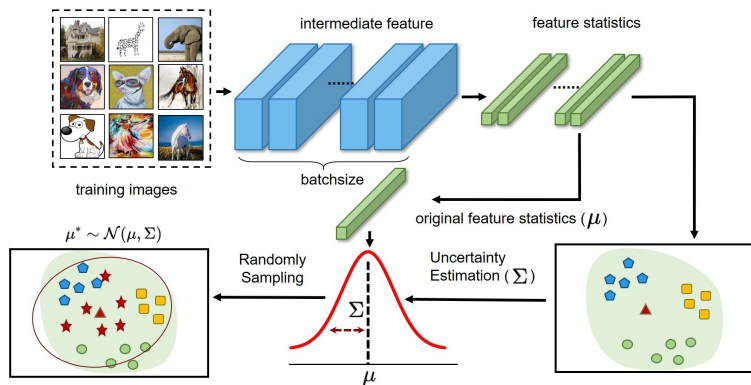

Under the assumption that the feature statistics of each source data distribution follows a multivariate Gaussian distribution, DSU models the uncertainty of domain shifts with synthesized feature statistics during training.

MatchDG: Build Representations via Causal Matching

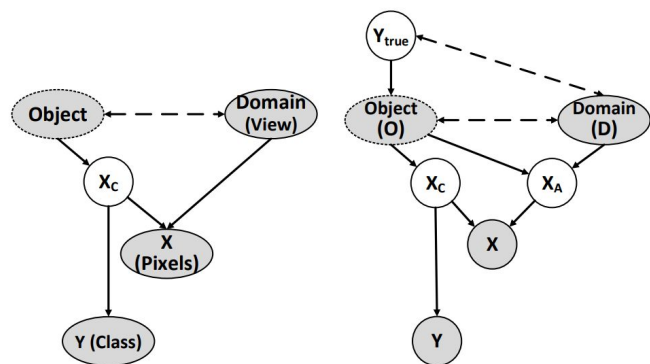

MatchDG utilizes contrastive learning to build a representation such that inputs sharing the same causal features are closer to one another.

Regularization Strategies

RSC: Representation Self-Challenging

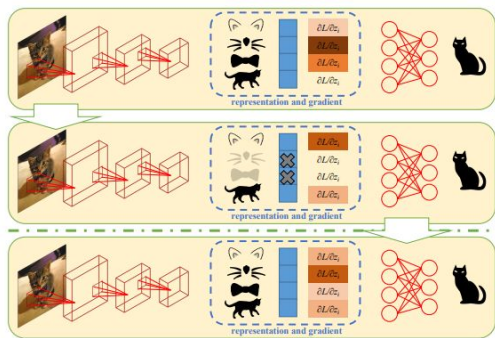

RSC mutes the feature representations associated with the highest gradient, such that the network is forced to predict the labels through other features

Huang et al. "Self-Challenging Improves Cross-Domain Generalization". ECCV 2020

CORAL: Correlation Alignment

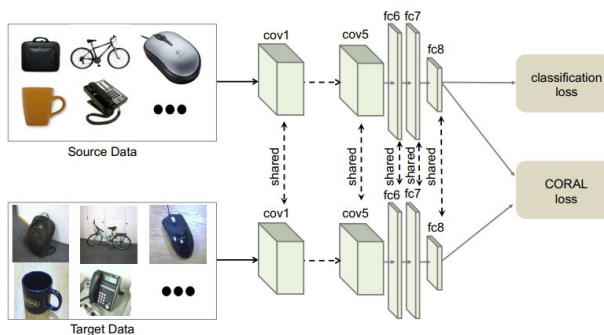

CORAL focuses on minimizing the distance between the second-order statistics (covariances) between domains.

Sun et al. "Deep CORAL: Correlation Alignment for Deep Domain Adaptation". ECCV 2016

FISHR: Regularization with Fisher Information

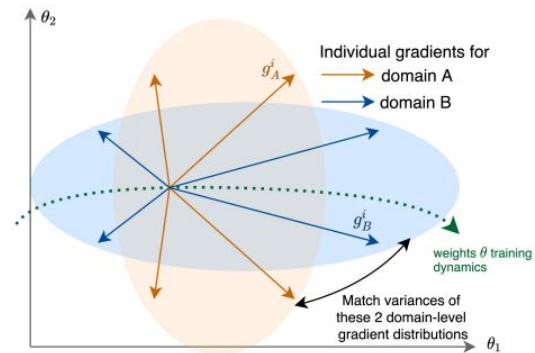

FISHR introduces a regularization term that matches the domain-level variances of gradients across training domains

Rame et al. "Fishr: Invariant gradient variances for out-of-distribution generalization." PMLR, 2022.

Learning algorithms

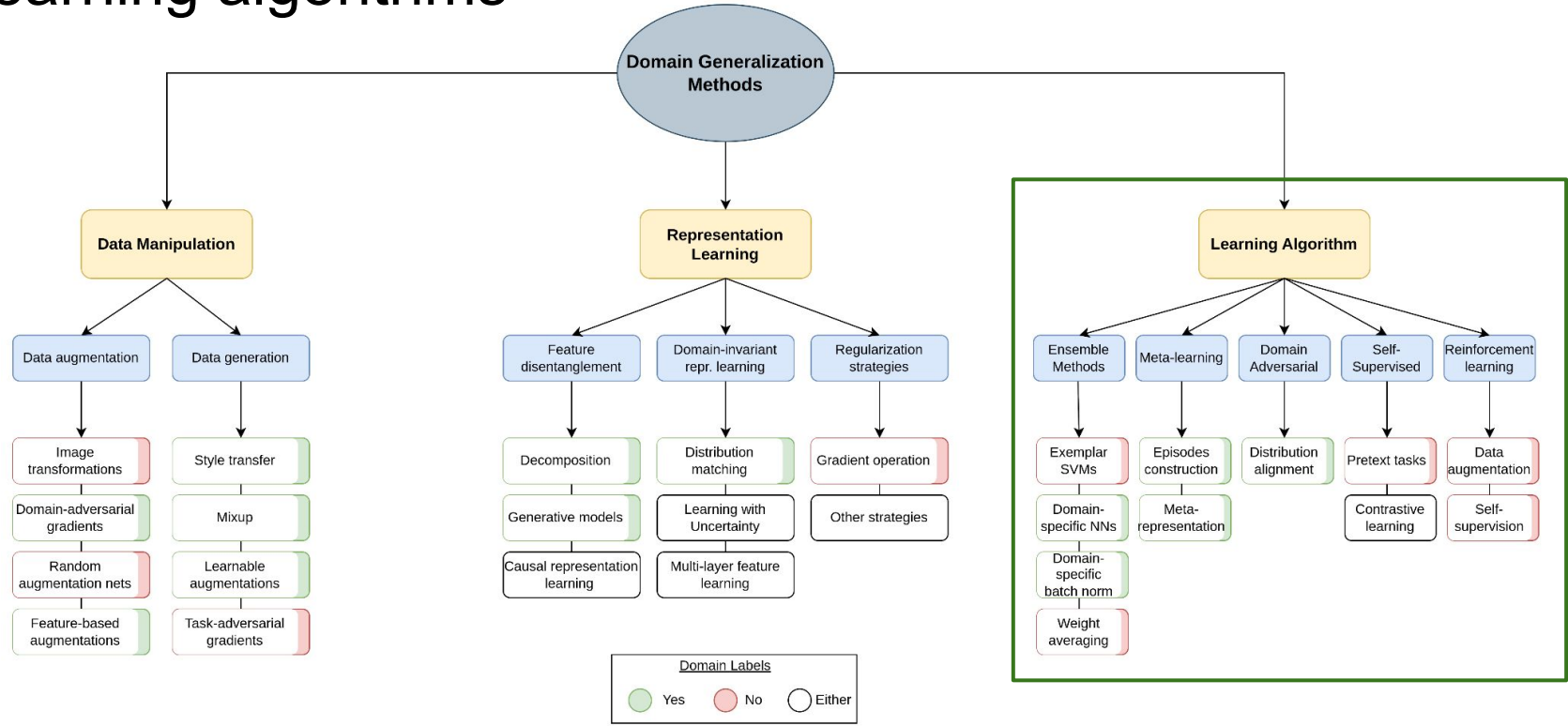

This taxonomy is a variation / extension of the ones on Wang, J. et al. "Generalizing to unseen domains: A survey on domain generalization." IEEE Transactions on Knowledge and Data Engineering (2022), and Zhou, Kaiyang, et al. "Domain generalization: A survey." IEEE Transactions on Pattern Analysis and Machine Intelligence (2022).

Meta-Learning

MLDG: Meta-Learning for DG

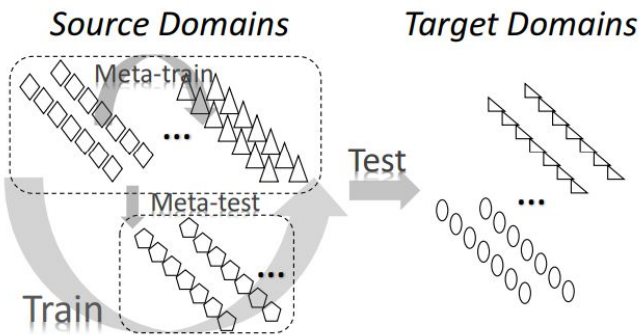

In each mini-batch a loss is computed based on evaluation on meta-test domains. This meta-test evaluation simulates testing on new domains with different statistics, thus improving robustness.

Li et al. Learning to generalize: Meta-learning for domain generalization. AAAI 2018.

MetaReg: Meta-Learning for regularization

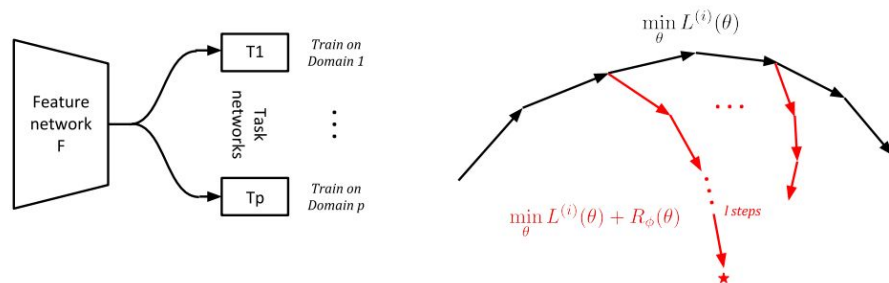

The goal is to learn a regularizer model from multiple domain-specific networks in order to update the parameters of the base classifier.

Balaji et al. "Metareg: Towards domain generalization using meta-regularization". NIPS 2018.

Ensemble Methods

MIRO: Mutual Information Regularization with Oracle

Algorithm 1: Mutual Information Regularization with Oracle (MIRO)

Input: feature extractor f , classifier g , mean encoder μ , variance encoder Σ , regularization coefficient λ , batch size N .

Init: initialize f to pre-trained feature extractor f^0 .

Output: learned feature extractor f and learned classifier g .

for sampled mini-batch (\mathbf{x}, \mathbf{y}) **do**

$\mathbf{z}_f = f(\mathbf{x})$

$\mathbf{z}_{f^0} = f^0(\mathbf{x})$

$\mathcal{L} =$

$\frac{1}{N} \sum_i^N [\text{CrossEntropy}(g(z_f^i), y^i) + \lambda (\log |\Sigma(z_f^i)| + \|z_{f^0}^i - \mu(z_f^i)\|_{\Sigma(z_f^i)}^2)]$

 update f, g, μ, Σ to minimize \mathcal{L}

end

In MIRO, a large pre-trained model is used as an “Oracle” model and is leveraged to guide a classifier by maximizing the Mutual Information between their representations.

Cha et al. "Domain generalization by mutual-information regularization with pre-trained models." ECCV 2022.

SIMPLE: Specialized Model-Sample Matching

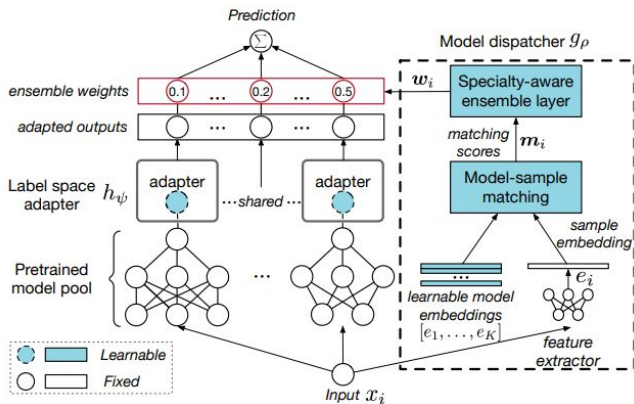

SIMPLE utilizes a pool of fixed pretrained models and selects the best subset for each downstream task/dataset.

Li et al. "SIMPLE: Specialized Model-Sample Matching for Domain Generalization." ICLR 2023.

Domain Adversarial Learning

MMLD: Mixture of Multiple Latent Domains

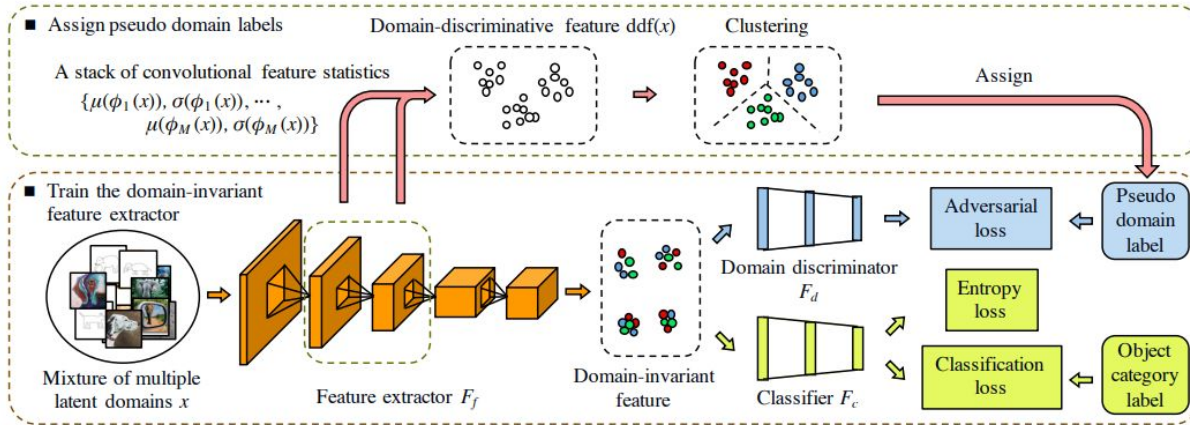

MMLD iteratively assigns pseudo domain labels by clustering domain discriminative features extracted from lower layers of the feature extractor, and trains the domain-invariant feature extractor via adversarial learning.

Self-Supervised Learning

SelfReg: Self-Supervised Contrastive Regularization

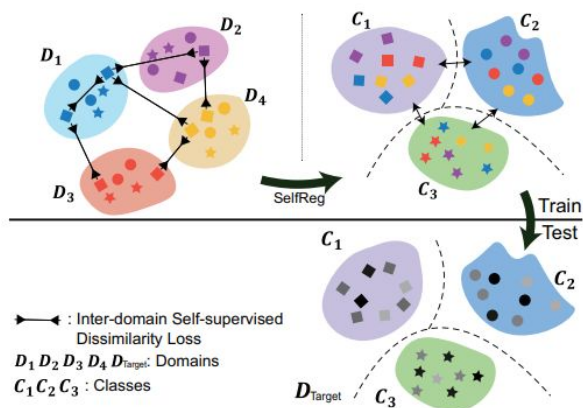

SelfReg maps the latent representations of same-class samples close together to learn domain-invariant properties.

Kim et al. "Selfreg: Self-supervised contrastive regularization for domain generalization". ICCV 2021.

PCL: Proxy-Based Contrastive Learning

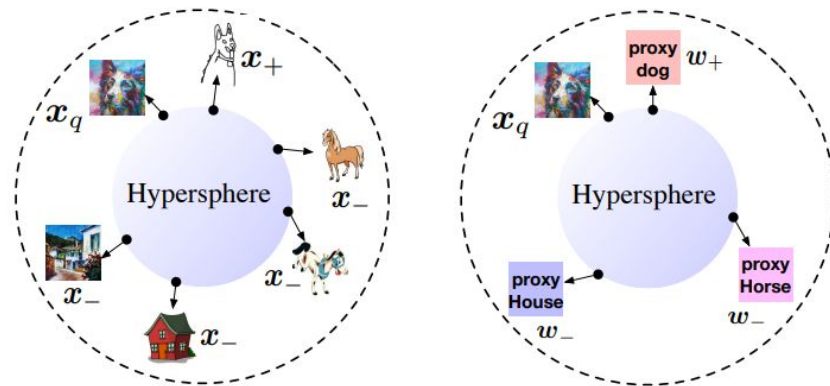

The PCL paper indicates that aligning positive sample-to-sample pairs hinders the model generalization and proposes aligning proxy-to-sample representations.

Yao et al. "Pcl: Proxy-based contrastive learning for domain generalization". CVPR 2022.

Part 3: Datasets and Benchmarks

DG Applications & Datasets

There are several applications and datasets which can be used for evaluating DG algorithms. To name a few:

Object Recognition

- PACS
- VLCS
- OfficeHome
- DomainNet
- WILDS
- TerraInc
- NICO++

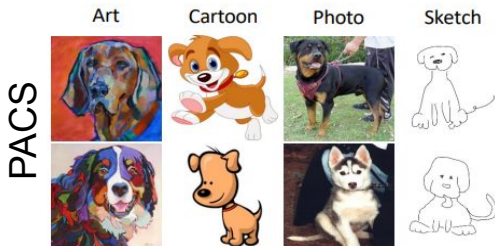

Action Recognition

- IXMAS
- UCF-HMDB

Sentiment Classification

- Amazon Reviews

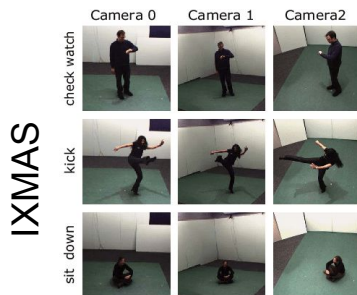

Medical Imaging

- Multi-site Prostate MRI Seg
- Chest X-rays

Reinforcement Learning

- Coinrun
- OpenAI Procgen

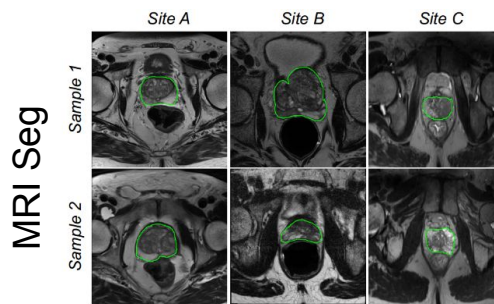

DG Benchmarks & Codebases (1)

Lately, the **DomainBed** benchmark for domain generalization image classification has been generally recognized and used by researchers.

The currently available datasets are:

- RotatedMNIST
- ColoredMNIST
- VLCS
- PACS
- Office-Home
- TerraIncognita
- DomainNet
- A SVIRO
- WILDS FMoW
- WILDS Camelyon17
- Spawrious

Algorithm	CMNIST	RMNIST	VLCS	PACS	Office-Home	TerraInc	DomainNet	Avg
ERM	34.2 ± 1.2	98.0 ± 0.0	76.8 ± 1.0	83.3 ± 0.6	67.3 ± 0.3	46.2 ± 0.2	40.8 ± 0.2	63.8
IRM	36.3 ± 0.4	97.7 ± 0.1	77.2 ± 0.3	82.9 ± 0.6	66.7 ± 0.7	44.0 ± 0.7	35.3 ± 1.5	62.9
DRO	32.2 ± 3.7	97.9 ± 0.1	77.5 ± 0.1	83.1 ± 0.6	67.1 ± 0.3	42.5 ± 0.2	32.8 ± 0.2	61.8
Mixup	31.2 ± 2.1	98.1 ± 0.1	78.6 ± 0.2	83.7 ± 0.9	68.2 ± 0.3	46.1 ± 1.6	39.4 ± 0.3	63.6
MLDG	36.9 ± 0.2	98.0 ± 0.1	77.1 ± 0.6	82.4 ± 0.7	67.6 ± 0.3	45.8 ± 1.2	42.1 ± 0.1	64.2
CORAL	29.9 ± 2.5	98.1 ± 0.1	77.0 ± 0.5	83.6 ± 0.6	68.6 ± 0.2	48.1 ± 1.3	41.9 ± 0.2	63.9
MMD	42.6 ± 3.0	98.1 ± 0.1	76.7 ± 0.9	82.8 ± 0.3	67.1 ± 0.5	46.3 ± 0.5	39.3 ± 0.9	64.7
DANN	29.0 ± 7.7	89.1 ± 5.5	77.7 ± 0.3	84.0 ± 0.5	65.5 ± 0.1	45.7 ± 0.8	37.5 ± 0.2	61.2
C-DANN	31.1 ± 8.5	96.3 ± 1.0	74.0 ± 1.0	81.7 ± 1.4	64.7 ± 0.4	40.6 ± 1.8	38.7 ± 0.2	61.1

Gulrajani et al. "In search of lost domain generalization." arXiv 2020.
Code: <https://github.com/facebookresearch/DomainBed>

Sidenote: Example of method outperforming ERM on average

Algorithm	Accuracy (\uparrow)								Ranking (\downarrow)		
	CMNIST	RMNIST	VLCS	PACS	OfficeHome	TerraInc	DomainNet	Avg	Arith. mean	Geom. mean	Median
ERM	57.8 \pm 0.2	97.8 \pm 0.1	77.6 \pm 0.3	86.7 \pm 0.3	66.4 \pm 0.5	53.0 \pm 0.3	41.3 \pm 0.1	68.7	9.1	8.1	8
IRM	<u>67.7</u> \pm 1.2	97.5 \pm 0.2	76.9 \pm 0.6	84.5 \pm 1.1	63.0 \pm 2.7	50.5 \pm 0.7	28.0 \pm 5.1	66.9	14.7	12.4	16
GroupDRO	61.1 \pm 0.9	97.9 \pm 0.1	77.4 \pm 0.5	87.1 \pm 0.1	66.2 \pm 0.6	52.4 \pm 0.1	33.4 \pm 0.3	67.9	8.6	7.5	8
Mixup	58.4 \pm 0.2	<u>98.0</u> \pm 0.1	78.1 \pm 0.3	86.8 \pm 0.3	68.0 \pm 0.2	54.4 \pm 0.3	39.6 \pm 0.1	69.0	5.3	3.9	4
MLDG	58.2 \pm 0.4	97.8 \pm 0.1	77.5 \pm 0.1	86.8 \pm 0.4	66.6 \pm 0.3	52.0 \pm 0.1	41.6 \pm 0.1	68.7	9.1	8.2	9
CORAL	58.6 \pm 0.5	<u>98.0</u> \pm 0.0	77.7 \pm 0.2	87.1 \pm 0.5	68.4 \pm 0.2	52.8 \pm 0.2	<u>41.8</u> \pm 0.1	<u>69.2</u>	<u>4.6</u>	<u>3.4</u>	<u>3</u>
MMD	63.3 \pm 1.3	<u>98.0</u> \pm 0.1	77.9 \pm 0.1	87.2 \pm 0.1	66.2 \pm 0.3	52.0 \pm 0.4	23.5 \pm 9.4	66.9	7.0	4.9	6
DANN	57.0 \pm 1.0	97.9 \pm 0.1	<u>79.7</u> \pm 0.5	85.2 \pm 0.2	65.3 \pm 0.8	50.6 \pm 0.4	38.3 \pm 0.1	67.7	11.9	9.6	15
CDANN	59.5 \pm 2.0	97.9 \pm 0.0	79.9 \pm 0.2	85.8 \pm 0.8	65.3 \pm 0.5	50.8 \pm 0.6	38.5 \pm 0.2	68.2	9.6	7.4	10
MTL	57.6 \pm 0.3	97.9 \pm 0.1	77.7 \pm 0.5	86.7 \pm 0.2	66.5 \pm 0.4	52.2 \pm 0.4	40.8 \pm 0.1	68.5	8.4	7.8	7
SagNet	58.2 \pm 0.3	97.9 \pm 0.0	77.6 \pm 0.1	86.4 \pm 0.4	67.5 \pm 0.2	52.5 \pm 0.4	40.8 \pm 0.2	68.7	8.0	7.2	6
ARM	63.2 \pm 0.7	98.1 \pm 0.1	77.8 \pm 0.3	85.8 \pm 0.2	64.8 \pm 0.4	51.2 \pm 0.5	36.0 \pm 0.2	68.1	9.9	7.5	12
V-REx	67.0 \pm 1.3	97.9 \pm 0.1	78.1 \pm 0.2	87.2 \pm 0.6	65.7 \pm 0.3	51.4 \pm 0.5	30.1 \pm 3.7	68.2	7.7	5.5	5
RSC	58.5 \pm 0.5	97.6 \pm 0.1	77.8 \pm 0.6	86.2 \pm 0.5	66.5 \pm 0.6	52.1 \pm 0.2	38.9 \pm 0.6	68.2	9.9	9.4	9
AND-mask	58.6 \pm 0.4	97.5 \pm 0.0	76.4 \pm 0.4	86.4 \pm 0.4	66.1 \pm 0.2	49.8 \pm 0.4	37.9 \pm 0.6	67.5	13.4	13.1	12
SAND-mask	62.3 \pm 1.0	97.4 \pm 0.1	76.2 \pm 0.5	85.9 \pm 0.4	65.9 \pm 0.5	50.2 \pm 0.1	32.2 \pm 0.6	67.2	14.3	13.5	15
Fish	61.8 \pm 0.8	97.9 \pm 0.1	77.8 \pm 0.6	85.8 \pm 0.6	66.0 \pm 2.9	50.8 \pm 0.4	43.4 \pm 0.3	69.1	8.4	6.6	7
Fishr	68.8 \pm 1.4	97.8 \pm 0.1	78.2 \pm 0.2	86.9 \pm 0.2	<u>68.2</u> \pm 0.2	<u>53.6</u> \pm 0.4	<u>41.8</u> \pm 0.2	70.8	3.9	2.8	2

DG Benchmarks & Codebases (2)

WILDS is a collection of benchmark datasets that represent distribution shifts faced in the wild.

WILDS provides the following datasets:

- iWildCAM
- Camelyon17
- VLCS
- RxRx1
- OGB-MolPCBA
- GlobalWheat
- DomainNet
- CivilComments
- FMoW
- PovertyMap
- Amazon
- Py150

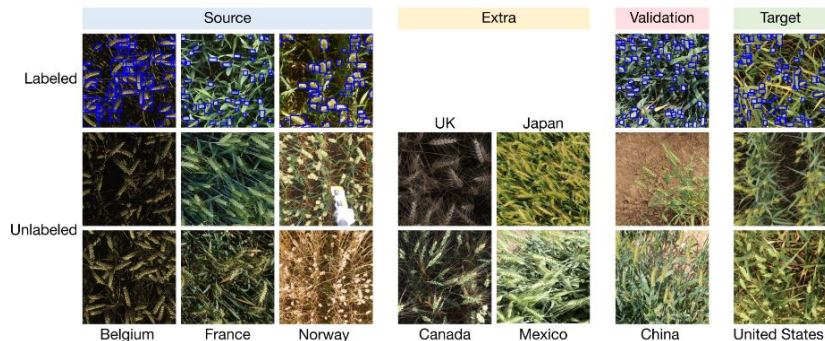
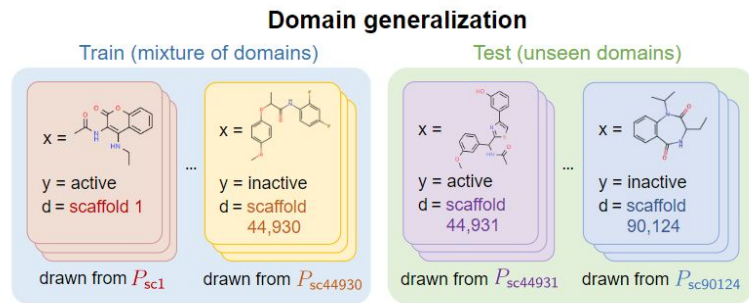

Koh et al. "Wilds: A benchmark of in-the-wild distribution shifts." PMLR 2021.
Code: <https://github.com/p-lambda/wilds/>

DG Benchmarks & Codebases (3)

NICO++ is specifically designed for OOD (Out-of-Distribution) image classification. It simulates a real world setting that the testing distribution may induce arbitrary shifting from the training distribution



DG Benchmarks & Codebases (4)

Building on DomainBed, additional benchmarks have been proposed.

OoD-Bench adopts similar datasets to DomainBed and splits the benchmark into two dimensions, focusing on data suffering from either *diversity* or *correlation* shift.

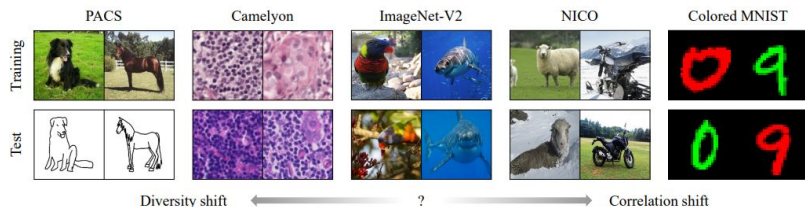

Ye et al. "Ood-bench: Quantifying and understanding two dimensions of out-of-distribution generalization." CVPR 2022.

Code: https://github.com/ynysjtu/ood_bench

DeepDG is proposed as a simplified version of DomainBed with additional features.

Specifically it:

- Avoids huge hyperparameter tuning
- Provides a more friendly interface and
- Has better customization

J. Wang et al., "Generalizing to Unseen Domains: A Survey on Domain Generalization". IEEE TKDE 2022

Code: <https://github.com/jindongwang/transferlearning>

Part 4: Application to biomedical signals and the BioDG benchmark

Domain Generalization in Biosignal Classification

Up until now, we have presented an abundance of methods / datasets / benchmarks for the DG problem regarding images.

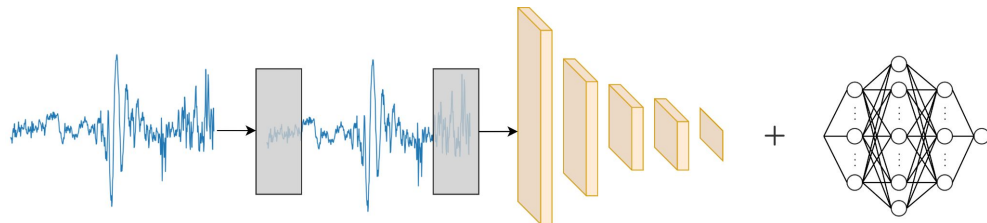

*The DG problem is somewhat under-researched in other settings such as **Biosignal Classification**.*

Distributional shifts can occur due to:

- Different hospital equipment
- Different or evolving hospital procedures
- Different testing environments
- Different physiology of patients

Biosignal Classification in General

We consider domain generalization for the **12-lead ECG** and **62-channel EEG** classification task and aim to improve the ability of a model $M_\theta : X \rightarrow Y$ to detect domain-invariant features of a class.

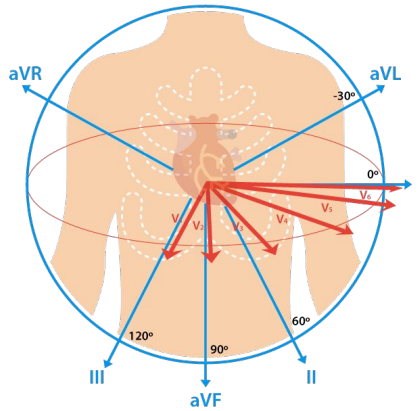

12-Lead ECG. [source](#)

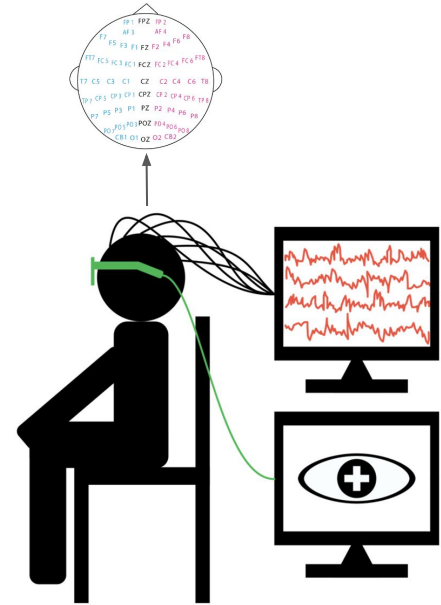

62-channel EEG. [source](#)

Visualizations of 12-lead ECG and 62-channel EEG signals.

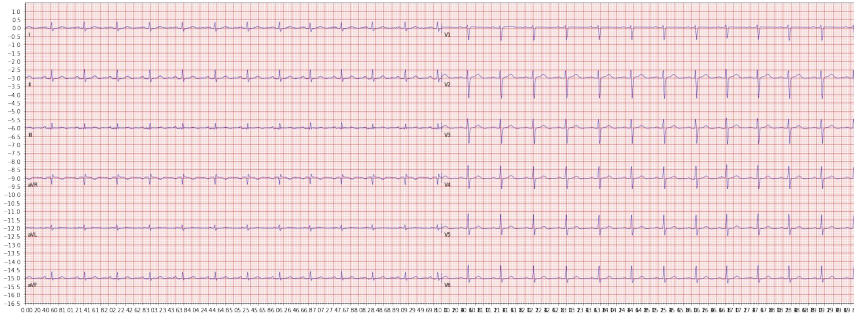

Typical 12-lead electrocardiogram.



Spike and wave discharges monitored EEG

The BioDG Benchmark (1)

We introduce a novel DG open-source evaluation benchmark, namely **BioDG** for the biosignal classification setting.

Specifically, BioDG:

- Proposes a DG setup for ECG and EEG classification, using datasets from [PhysioNet](#) and [SEED](#)
- Adapts state-of-the-art image DG algorithms to 1D signal classification and
- Provides researchers with the means to pour further research in biomedical DG.

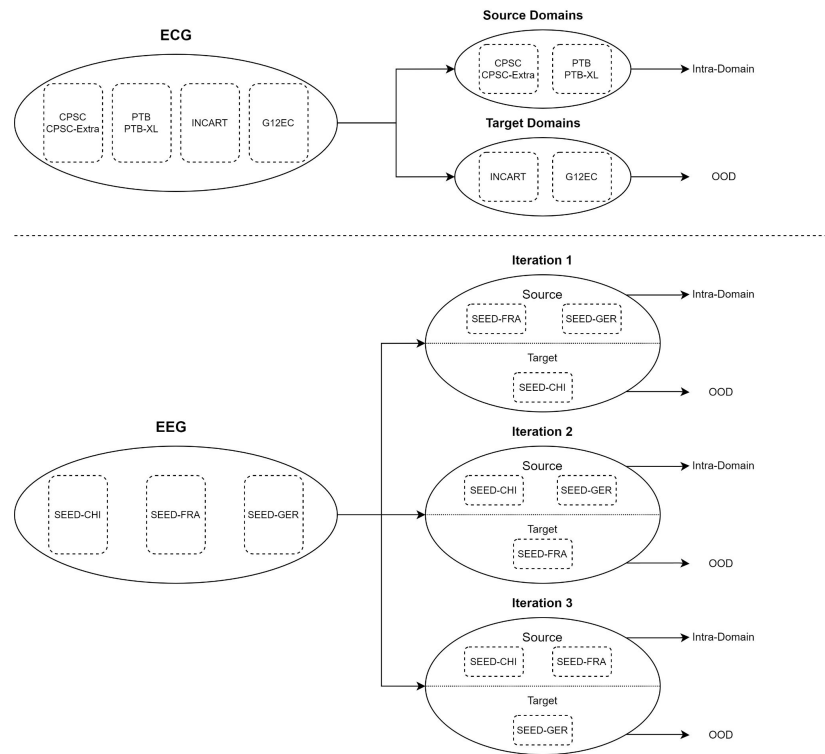

The BioDG Benchmark (2)

For the DG setup, we used publicly available datasets from the PhysioNet (ECG) and SEED (EEG) repositories.

ECG

We used datasets from 4 different sources:

- CPSC, CPSC Extra
- G12EC
- INCART
- PTB, PTB-XL

The ECG signals are multi-class and multi-label (24 labels).

Task: Disease prediction

Alday et al. "Classification of 12-lead ecgs: the physionet/computing in cardiology challenge 2020." Physiological measurement 2020.

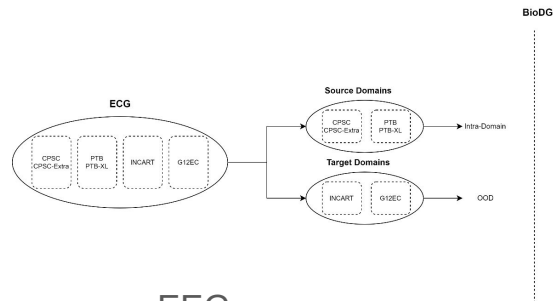

EEG

We used the datasets from 3 different populations:

- SEED-CHI
- SEED-FRA
- SEED-GER

The EEG signals are multi-class (3 labels) problem.

Task: Emotion classification

Zheng et al. "Investigating Critical Frequency Bands and Channels for EEG-Based Emotion Recognition with Deep Neural Networks". IEEE TAE 2015.

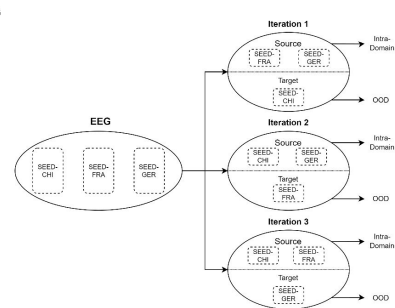

The BioDG Benchmark (3)

We also propose an alternative architecture to tackle DG in 1D biosignal classification, which utilizes representations from multiple intermediate layers of a backbone ResNet model.

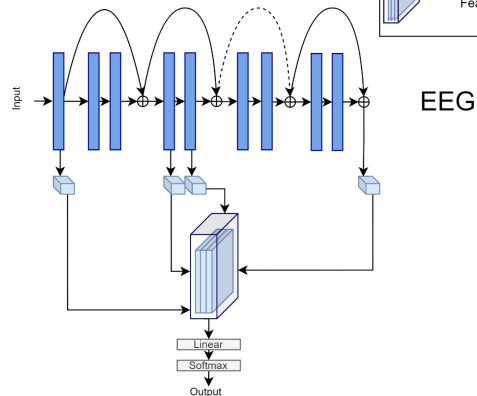
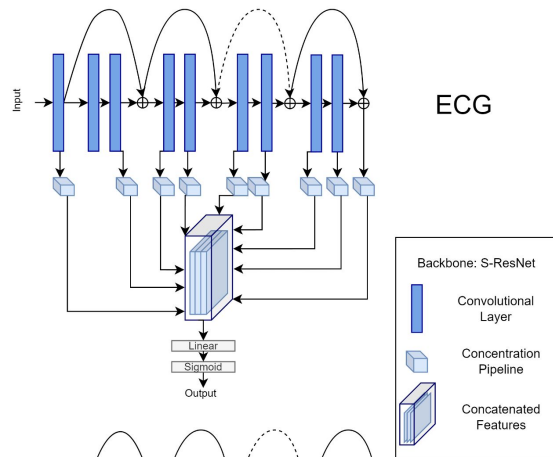
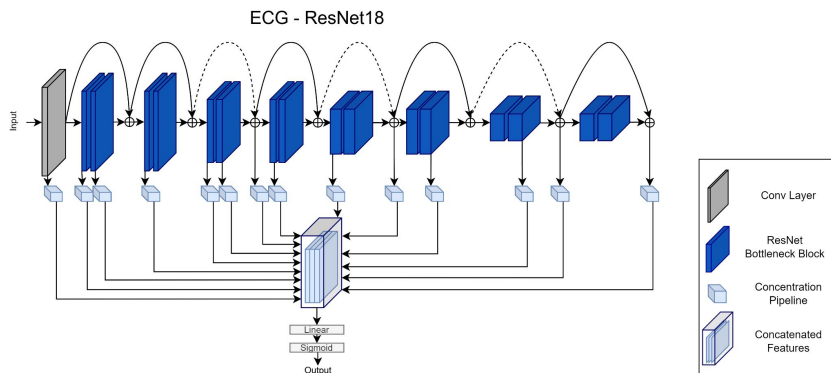

Ballas and Diou. "Towards Domain Generalization for ECG and EEG Classification: Algorithms and Benchmarks.", IEEE TETCI 2023
Code: <https://github.com/aristotelisballas/biodg>

The BioDG baseline models

The BioDG Benchmark (4)

BioDG provides evaluation metrics for both Intra-Distribution and Out-of-Distribution data splits.

Clearly, we have a long way to go.

ECG Classification Results

Backbone: S-ResNet	Intra-Distribution						OOD					
	ERM	IRM	MMD	RSC	CORAL	BioDG	ERM	IRM	MMD	RSC	CORAL	BioDG
Diagnosis												
1st degree AV block	16.14	0	7.69	15.00	10.67	61.88	7.30	0	5.84	0.51	7.38	62.24
Atrial fibrillation	55.84	18.18	23.98	36.99	24.81	87.05	32.58	12.16	13.28	12.16	13.22	62.51
Atrial flutter	19.05	0	0	13.33	0	50.00	0	0	0	0	0	10.70
Bradycardia	0	0	0	5.26	7.69	0	0	0	0	0	0	0
Complete right bundle branch block	73.38	16.16	60.41	72.58	64.19	82.46	60.15	11.50	50.90	47.75	52.64	64.55
Incomplete right bundle branch block	11.01	0	13.05	4.86	22.19	43.03	14.56	0	20.09	10.85	25.65	30.27
Left anterior fascicular block	54.67	0	50.83	52.8	53.37	70.29	31.03	0	21.01	17.16	20.84	33.29
Left axis deviation	58.10	31.15	58.34	56.26	60.56	66.87	44.98	17.79	37.75	36.09	39.16	50.42
Left bundle branch block	80.49	0	0	78.33	45.49	85.48	62.44	0	0	0	40	74.04
Low QRS voltages	0	0	0	0	0	0	0	0	0	0	0	0
Non-specific intraventricular conduction disorder	0	0	0	4.55	0	2.34	0	0	0	0	0	0
Pacing rhythm	58.62	0	37.84	43.90	48.15	78.46	0	0	0	0	0	0
Premature ventricular contractions	0	0	0	0	0	0	0	0	0	0	0	0
Prolonged PR interval	0	0	0	0	0	15.00	0	0	0	0	0	0
Prolonged QT interval	0	0	0	0	0	0	0	0	0	0	0	0
Q wave abnormal	0	0	0	0	0	14.11	0	0	0	0	0	0
Right axis deviation	5.48	0	23.27	9.52	27.92	24.53	0	0	18.58	<u>21.54</u>	17.35	2.84
Sinus arrhythmia	2.17	0	0	0	0	0	1.94	0	0	0	0	10.85
Sinus bradycardia	4.49	0	0	9.03	0	36.70	31.56	31.56	31.56	31.56	31.56	47.33
Sinus rhythm	84.60	80.94	80.94	82.56	80.94	91.44	38.89	0	12.54	0.62	15.17	82.68
Sinus tachycardia	27.86	0	10.37	20	15.54	79.82	1.35	0	<u>9.98</u>	0	8.07	1.92
Supraventricular premature beats	9.27	0	10.07	11.28	8.17	3.68	0	0	<u>10.02</u>	0	6.26	5.84
T wave abnormal	18.57	15.68	28.62	13.31	26.14	33.89	8.11	<u>38.40</u>	37.22	0	30.35	4.53
T wave inversion	0	0	0	0	0	0	0	0	0	0	0	0
# of Predicted Classes	16	5	12	17	15	18	12	5	12	9	13	15
Macro-F1 (Predicted)	41.46	9.01	38.00	17.03	37.82	53.91	31.15	7.43	32.43	14.92	31.70	36.44
Macro-F1 (All)	31.10	6.75	28.50	12.77	28.37	40.44	19.47	4.64	20.27	9.33	19.81	22.77

EEG Classification Results

Method	Intra		
	FRA-GER	CHI-GER	CHI-FRA
ERM	70.94 ± 2.51	73.63 ± 2.08	76.10 ± 2.27
IRM	70.75 ± 2.81	71.42 ± 2.98	73.90 ± 3.15
CORAL	71.42 ± 1.67	73.72 ± 1.91	74.96 ± 2.59
MMD	71.23 ± 2.23	74.34 ± 1.87	76.26 ± 1.95
RSC	70.15 ± 2.43	72.01 ± 2.37	76.15 ± 2.08
BioDG	77.59 ± 2.23	76.11 ± 1.25	<u>75.61</u> ± 1.15
Method	OOD		
	CHI	FRA	GER
ERM	54.60 ± 3.44	45.83 ± 3.53	63.75 ± 4.01
IRM	53.70 ± 1.42	43.82 ± 0.75	66.87 ± 3.49
CORAL	53.18 ± 3.29	45.00 ± 2.51	<u>67.04</u> ± 3.27
MMD	54.17 ± 2.68	45.80 ± 3.46	66.04 ± 3.39
RSC	53.86 ± 2.55	44.37 ± 2.99	58.79 ± 3.93
BioDG	57.09 ± 0.44	51.74 ± 0.35	68.04 ± 0.24

Some of our other works

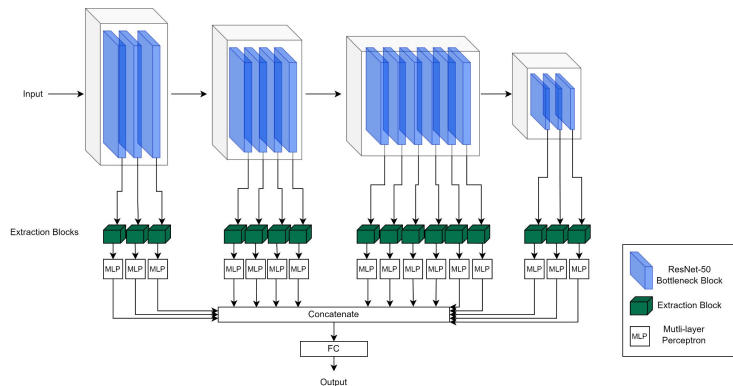

Ballas, Aristotelis, and Christos Diou. "Multi-Scale and Multi-Layer Contrastive Learning for Domain Generalization" *Under Review at IEEE TAI, 2023.*

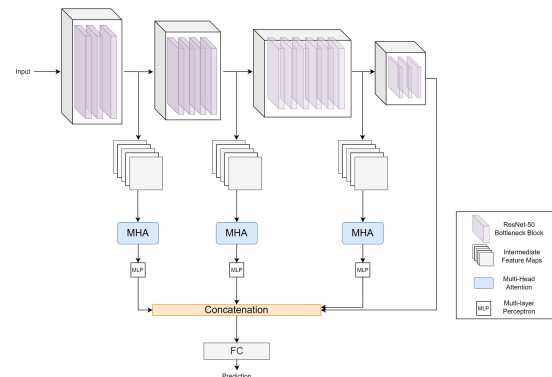

Ballas, Aristotelis, and Christos Diou. "CNNs with Multi-Level Attention for Domain Generalization." *ICMR 2023.*

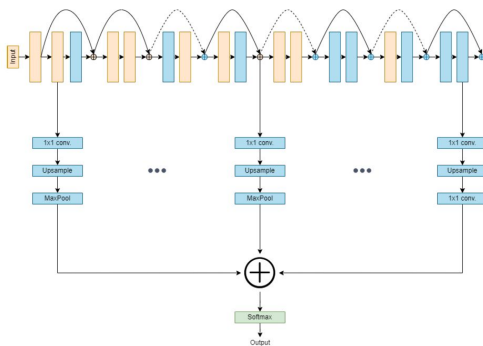

Ballas, Aristotelis, and Christos Diou. "Multi-layer Representation Learning for Robust OOD Image Classification." *SETN 2022.*



Ballas, Aristotelis, and Christos Diou. "CNN Feature Map Augmentation for Single-Source Domain Generalization." *BDS 2023.*

Presented on Wednesday.

Conclusions

Recap

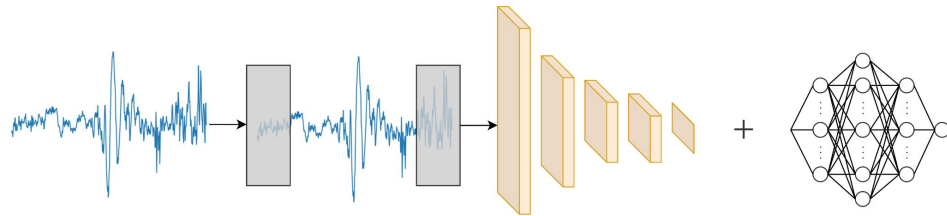
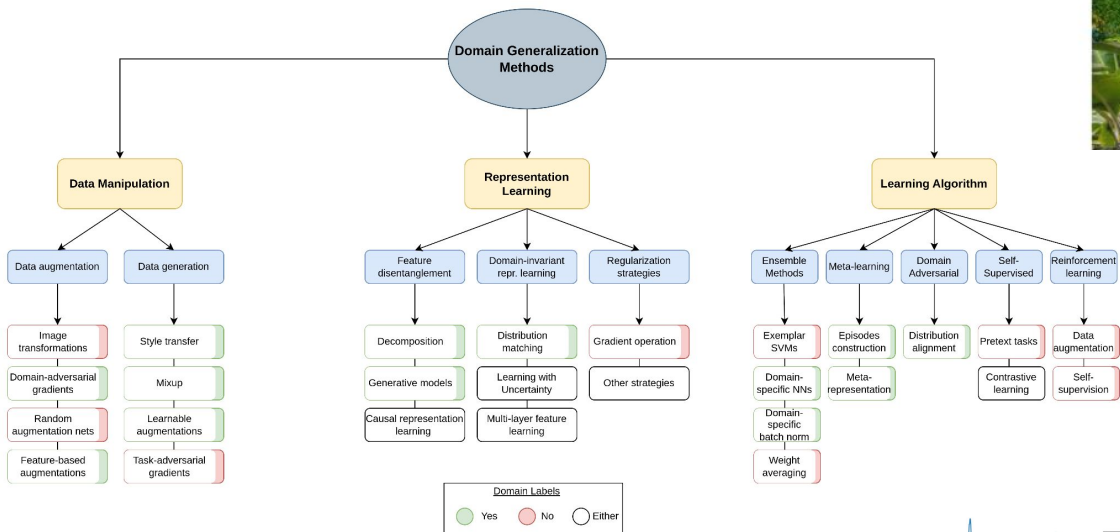

Future directions

- DG remains an open problem
 - Effectiveness of methods remains low compared to training with i.i.d. data
- Applies to several application areas
 - Many of them still unexplored
- Several subproblems emerge
 - Federated DG
- Several links to model explainability, model testing / assessment of robustness and bias

Thank you!



<https://bds-dgtutorial.github.io/>

References

- [1] A. A. Deshmukh, Y. Lei, S. Sharma, U. Dogan, J. W. Cutler, and C. Scott, “A generalization error bound for multi-class domain generalization,” *arXiv preprint arXiv:1905.10392*, 2019.
- [2] E. A. P. Alday *et al.*, “Classification of 12-lead ECGs: the PhysioNet/Computing in Cardiology Challenge 2020,” *Physiol. Meas.*, vol. 41, no. 12, p. 124003, Dec. 2020, doi: 10.1088/1361-6579/abc960.
- [3] B. Sun and K. Saenko, “Deep CORAL: Correlation Alignment for Deep Domain Adaptation,” in *Computer Vision – ECCV 2016 Workshops*, G. Hua and H. Jégou, Eds., in Lecture Notes in Computer Science, vol. 9915. Cham: Springer International Publishing, 2016, pp. 443–450. doi: 10.1007/978-3-319-49409-8_35.
- [4] J. Cha, K. Lee, S. Park, and S. Chun, “Domain Generalization by Mutual-Information Regularization with Pre-trained Models,” in *Computer Vision – ECCV 2022*, S. Avidan, G. Brostow, M. Cissé, G. M. Farinella, and T. Hassner, Eds., in Lecture Notes in Computer Science, vol. 13683. Cham: Springer Nature Switzerland, 2022, pp. 440–457. doi: 10.1007/978-3-031-20050-2_26.
- [5] F. M. Carlucci, A. D’Innocente, S. Bucci, B. Caputo, and T. Tommasi, “Domain Generalization by Solving Jigsaw Puzzles,” in *2019 IEEE/CVF Conference on Computer Vision and Pattern Recognition (CVPR)*, Long Beach, CA, USA: IEEE, Jun. 2019, pp. 2224–2233. doi: 10.1109/CVPR.2019.00233.
- [6] T. Matsuura and T. Harada, “Domain generalization using a mixture of multiple latent domains,” in *Proceedings of the AAAI Conference on Artificial Intelligence*, 2020, pp. 11749–11756.
- [7] D. Mahajan, S. Tople, and A. Sharma, “Domain Generalization using Causal Matching,” in *Proceedings of the 38th International Conference on Machine Learning*, PMLR, Jul. 2021, pp. 7313–7324. Accessed: Jul. 16, 2023. [Online]. Available: <https://proceedings.mlr.press/v139/mahajan21b.html>
- [8] K. Zhou, Y. Yang, Y. Qiao, and T. Xiang, “Domain Generalization with MixStyle,” in *International Conference on Learning Representations*, 2021. [Online]. Available: <https://openreview.net/forum?id=6xHJ37MVxxp>
- [9] X. Yue, Y. Zhang, S. Zhao, A. Sangiovanni-Vincentelli, K. Keutzer, and B. Gong, “Domain Randomization and Pyramid Consistency: Simulation-to-Real Generalization Without Accessing Target Domain Data,” in *2019 IEEE/CVF International Conference on Computer Vision (ICCV)*, Seoul, Korea (South): IEEE, Oct. 2019, pp. 2100–2110. doi: 10.1109/ICCV.2019.00219.
- [10] W. Wang, “DomainMix: Learning Generalizable Person Re-Identification Without Human Annotations”.

References

- [11] A. Rame, C. Dancette, and M. Cord, “Fishr: Invariant Gradient Variances for Out-of-Distribution Generalization,” in *Proceedings of the 39th International Conference on Machine Learning*, PMLR, Jun. 2022, pp. 18347–18377. Accessed: Jul. 16, 2023. [Online]. Available: <https://proceedings.mlr.press/v162/rame22a.html>
- [12] N. Somavarapu, C.-Y. Ma, and Z. Kira, “Frustratingly simple domain generalization via image stylization,” *arXiv preprint arXiv:2006.11207*, 2020.
- [13] S. Shankar, V. Piratla, S. Chakrabarti, S. Chaudhuri, P. Jyothi, and S. Sarawagi, “Generalizing Across Domains via Cross-Gradient Training,” in *International Conference on Learning Representations*, 2018. [Online]. Available: <https://openreview.net/forum?id=r1Dx7fbCW>
- [14] J. Wang *et al.*, “Generalizing to Unseen Domains: A Survey on Domain Generalization,” *IEEE Transactions on Knowledge and Data Engineering*, vol. 35, no. 8, pp. 8052–8072, Aug. 2023, doi: 10.1109/TKDE.2022.3178128.
- [15] I. Gulrajani and D. Lopez-Paz, “In search of lost domain generalization,” *arXiv preprint arXiv:2007.01434*, 2020.
- [16] W.-L. Zheng and B.-L. Lu, “Investigating Critical Frequency Bands and Channels for EEG-based Emotion Recognition with Deep Neural Networks,” *IEEE Transactions on Autonomous Mental Development*, vol. 7, no. 3, pp. 162–175, 2015, doi: 10.1109/TAMD.2015.2431497.
- [17] D. Li, Y. Yang, Y.-Z. Song, and T. Hospedales, “Learning to generalize: Meta-learning for domain generalization,” in *Proceedings of the AAAI conference on artificial intelligence*, 2018.
- [18] K. Zhou, Y. Yang, T. Hospedales, and T. Xiang, “Learning to Generate Novel Domains for Domain Generalization,” in *Computer Vision – ECCV 2020*, A. Vedaldi, H. Bischof, T. Brox, and J.-M. Frahm, Eds., in *Lecture Notes in Computer Science*, vol. 12361. Cham: Springer International Publishing, 2020, pp. 561–578. doi: 10.1007/978-3-030-58517-4_33.
- [19] F. Qiao, L. Zhao, and X. Peng, “Learning to Learn Single Domain Generalization,” in *2020 IEEE/CVF Conference on Computer Vision and Pattern Recognition (CVPR)*, Seattle, WA, USA: IEEE, Jun. 2020, pp. 12553–12562. doi: 10.1109/CVPR42600.2020.01257.
- [20] Y. Balaji, S. Sankaranarayanan, and R. Chellappa, “MetaReg: Towards Domain Generalization using Meta-Regularization,” in *Advances in Neural Information Processing Systems*, S. Bengio, H. Wallach, H. Larochelle, K. Grauman, N. Cesa-Bianchi, and R. Garnett, Eds., Curran Associates, Inc., 2018. [Online]. Available: <https://proceedings.neurips.cc/paper/2018/file/647bba344396e7c8170902bcf2e15551-Paper.pdf>

References

- [21] X. Zhang, Y. He, R. Xu, H. Yu, Z. Shen, and P. Cui, “NICO++: Towards Better Benchmarking for Domain Generalization.” 2023. [Online]. Available: <https://openreview.net/forum?id=q08xe1w1HA1>
- [22] N. Ye *et al.*, “OoD-Bench: Quantifying and Understanding Two Dimensions of Out-of-Distribution Generalization,” in *2022 IEEE/CVF Conference on Computer Vision and Pattern Recognition (CVPR)*, New Orleans, LA, USA: IEEE, Jun. 2022, pp. 7937–7948. doi: 10.1109/CVPR52688.2022.00779.
- [23] X. Yao *et al.*, “PCL: Proxy-based Contrastive Learning for Domain Generalization,” in *2022 IEEE/CVF Conference on Computer Vision and Pattern Recognition (CVPR)*, New Orleans, LA, USA: IEEE, Jun. 2022, pp. 7087–7097. doi: 10.1109/CVPR52688.2022.00696.
- [24] G. Zhang, H. Zhao, Y. Yu, and P. Poupart, “Quantifying and Improving Transferability in Domain Generalization,” in *Advances in Neural Information Processing Systems*, Curran Associates, Inc., 2021, pp. 10957–10970. Accessed: Jul. 16, 2023. [Online]. Available: <https://proceedings.neurips.cc/paper/2021/hash/5adaacd4531b78ff8b5cedfe3f4d5212-Abstract.html>
- [25] S. Beery, G. Van Horn, and P. Perona, “Recognition in Terra Incognita,” in *Computer Vision – ECCV 2018*, V. Ferrari, M. Hebert, C. Sminchisescu, and Y. Weiss, Eds., in Lecture Notes in Computer Science, vol. 11220. Cham: Springer International Publishing, 2018, pp. 472–489. doi: 10.1007/978-3-030-01270-0_28.
- [26] Z. Xu, D. Liu, J. Yang, C. Raffel, and M. Niethammer, “Robust and Generalizable Visual Representation Learning via Random Convolutions.” arXiv, May 03, 2021. doi: 10.48550/arXiv.2007.13003.
- [27] Z. Wu, X. Wang, D. Lin, D. Lischinski, D. Cohen-Or, and H. Huang, “SAGNet: structure-aware generative network for 3D-shape modeling,” *ACM Trans. Graph.*, vol. 38, no. 4, p. 91:1-91:14, Jul. 2019, doi: 10.1145/3306346.3322956.
- [28] Z. Huang, H. Wang, E. P. Xing, and D. Huang, “Self-challenging Improves Cross-Domain Generalization,” in *Computer Vision – ECCV 2020*, A. Vedaldi, H. Bischof, T. Brox, and J.-M. Frahm, Eds., in Lecture Notes in Computer Science. Cham: Springer International Publishing, 2020, pp. 124–140. doi: 10.1007/978-3-030-58536-5_8.
- [29] D. Kim, Y. Yoo, S. Park, J. Kim, and J. Lee, “SelfReg: Self-supervised Contrastive Regularization for Domain Generalization,” in *2021 IEEE/CVF International Conference on Computer Vision (ICCV)*, Montreal, QC, Canada: IEEE, Oct. 2021, pp. 9599–9608. doi: 10.1109/ICCV48922.2021.00948.
- [30] Z. Li, K. Ren, X. JIANG, Y. Shen, H. Zhang, and D. Li, “SIMPLE: Specialized Model-Sample Matching for Domain Generalization,” in *The Eleventh International Conference on Learning Representations*, 2023. [Online]. Available: https://openreview.net/forum?id=BqrPeZ_e5P
- [31] H. Ye, C. Xie, T. Cai, R. Li, Z. Li, and L. Wang, “Towards a Theoretical Framework of Out-of-Distribution Generalization,” in *Advances in Neural Information Processing Systems*, Curran Associates, Inc., 2021, pp. 23519–23531. Accessed: Jul. 16, 2023. [Online]. Available: <https://proceedings.neurips.cc/paper/2021/hash/c5c1cb0bebd56ae38817b251ad72bedb-Abstract.html>

References

- [32] H. Zhang, Y.-F. Zhang, W. Liu, A. Weller, B. Scholkopf, and E. P. Xing, “Towards Principled Disentanglement for Domain Generalization,” in *2022 IEEE/CVF Conference on Computer Vision and Pattern Recognition (CVPR)*, New Orleans, LA, USA: IEEE, Jun. 2022, pp. 8014–8024. doi: 10.1109/CVPR52688.2022.00786.
- [33] X. Li, Y. Dai, Y. Ge, J. Liu, Y. Shan, and L. DUAN, “Uncertainty Modeling for Out-of-Distribution Generalization,” in *International Conference on Learning Representations*, 2022.
- [34] P. W. Koh *et al.*, “WILDS: A Benchmark of in-the-Wild Distribution Shifts.” arXiv, Jul. 16, 2021. Accessed: Jul. 16, 2023. [Online]. Available: <http://arxiv.org/abs/2012.07421>

Acknowledgement

The work leading to these results has been funded by the European Union under Grant Agreements No. 101057821, project RELEVIVUM and European Union's Horizon 2020 research and innovation programme under Grant Agreement No. 965231, project REBECCA (REsearch on BrEaSt Cancer induced chronic conditions supported by Causal Analysis of multisource data).

